

Strut Channel

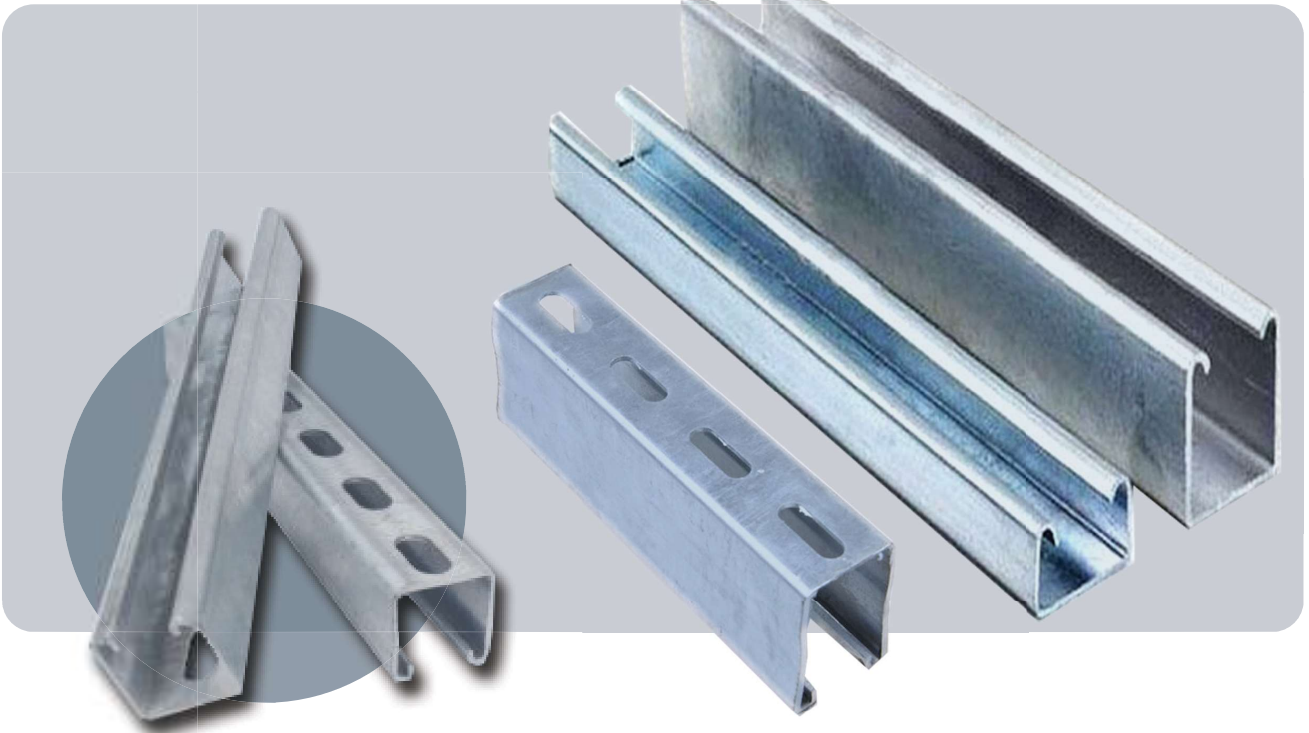

The strut system incorporates the following features

Flexibility of elements of the system can be combined to create an unlimited range of structural designs.

- Rigidity of easily assembled rigid structures can be created without the need for drilling and welding.
- Adjustability of position of components can be easily adjusted & structures can be demounted and components reused.
- Competitiveness & high strength to weight components and ease of assembly make this a cost effective solution to support structural requirements.
- It has many applications for structural support of mechanical as well as electrical services in a wide range of industries and construction projects.

The standard material finish for strut channel and brackets is HDG Hot Dip Galvanised.



Cable Ladder Support

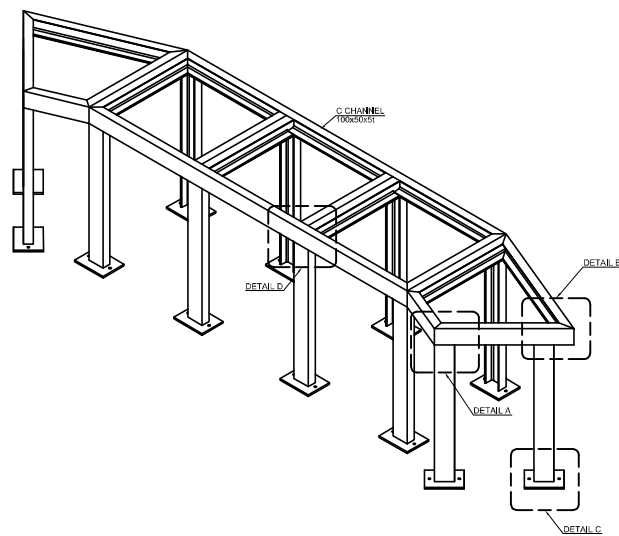
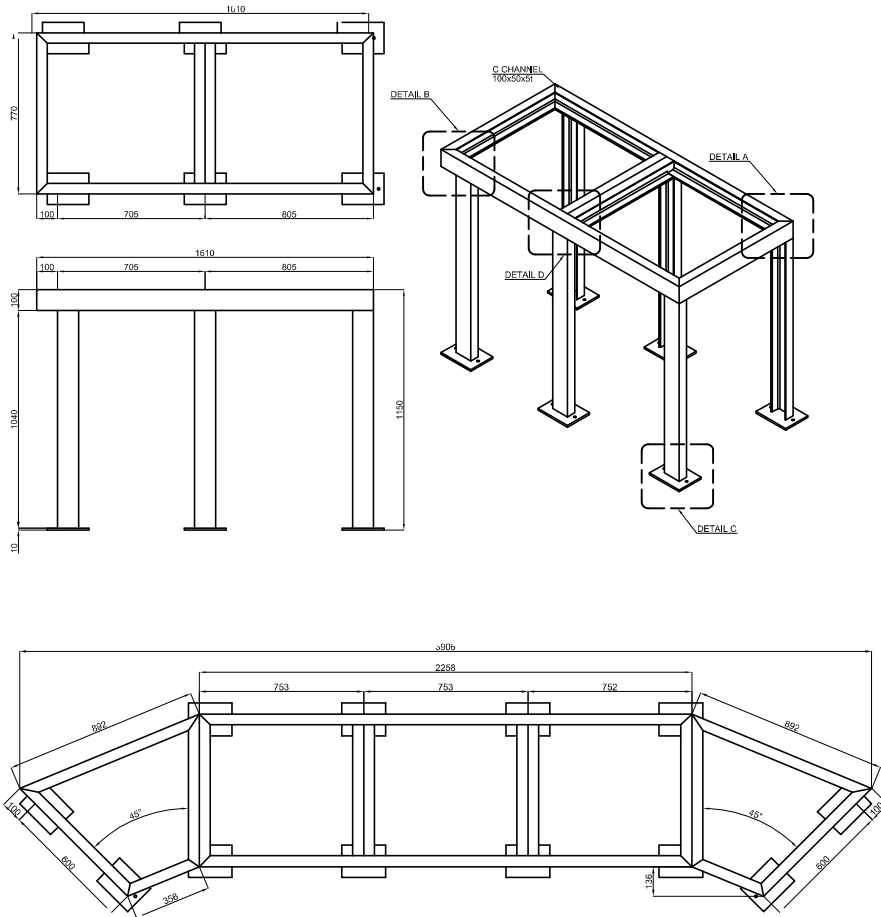

Cable Ladder Support

